

CORRENTE DE ROLOS SERIE EUROPEIA - DIN 8187 - ISO 606

ROLLER CHAINS EUROPEAN STANDARD - DIN 8187 - ISO 606

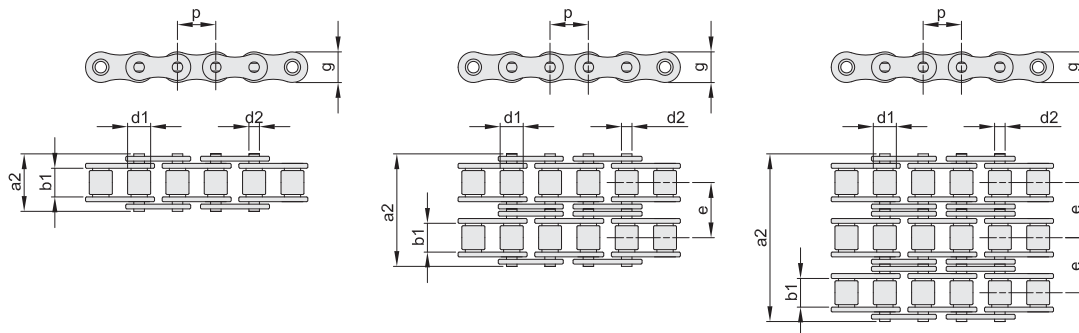

CORRENTE PRODUZIDA DE ACORDO COM NORMA ISO 9001 - ISO 14001 E API 7F
CHAIN PRODUCED BY ISO 9001 - ISO 14001 AND API 7F CERTIFIED COMPANY
CORRENTE PRÉ-TENSIONADA / PRE-STRETCHED CHAINS



SIMPLES

ISO	p		b ₁ mm min.	d ₂ mm	d ₁ mm max.	a ₂ mm max.	g mm max.	Carga de rotura		q kg/m ≈
	mm	inch						minimo KN	medio KN	
04-1	6	-	2,80	1,85	4,00	7,4	5,00	3,0	3,3	0,12
05B-1	8	-	3,00	2,31	5,00	8,6	7,11	5,0	5,9	0,18
06B-1	9,525	3/8"	5,72	3,28	6,35	13,5	8,26	9,0	10,7	0,40
084-1	12,7	1/2"	4,88	4,09	7,75	14,8	11,15	15,7	17,5	0,49
08B-1	12,7	1/2"	7,75	4,45	8,51	17,0	11,81	18,0	21,1	0,68
10B-1	15,875	5/8"	9,65	5,08	10,16	19,6	14,73	22,4	27,4	0,91
12B-1	19,05	3/4"	11,68	5,72	12,07	22,7	16,13	29,0	32,3	1,12
16B-1	25,4	1"	17,02	8,28	15,88	36,1	21,08	60,0	70,6	2,59
20B-1	31,75	1 1/4"	19,56	10,19	19,05	43,2	26,42	95,0	109,8	3,68
24B-1	38,1	1 1/2"	25,40	14,63	25,40	53,4	33,40	160,0	179,0	6,85
28B-1	44,45	1 3/4"	30,99	15,90	27,94	65,1	37,08	200,0	226,0	8,56
32B-1	50,8	2"	30,99	17,81	29,21	67,4	42,29	250,0	273,0	9,49
40B-1	63,5	2 1/2"	38,10	22,89	39,37	82,6	52,90	355,0	390,0	15,53

DUPLA

ISO	p		b ₁ mm min.	d ₂ mm	d ₁ mm max.	a ₂ mm max.	g mm max.	e mm	Carga de rotura		q kg/m ≈
	mm	inch							minimo KN	medio KN	
05B-2	8	-	3,00	2,31	5,00	14,3	7,11	5,64	7,8	8,5	0,32
06B-2	9,525	3/8"	5,72	3,28	6,35	23,8	8,26	10,24	16,9	19,2	0,76
08B-2	12,7	1/2"	7,75	4,45	8,51	31,0	11,81	13,92	32,0	38,0	1,31
10B-2	15,875	5/8"	9,65	5,08	10,16	36,2	14,73	16,59	44,5	57,3	1,79
12B-2	19,05	3/4"	11,68	5,72	12,07	42,2	16,13	19,46	57,8	65,7	2,22
16B-2	25,4	1"	17,02	8,28	15,88	68,0	21,08	31,88	113,7	137,5	5,03
20B-2	31,75	1 1/4"	19,56	10,19	19,05	79,7	26,42	36,45	170,0	210,0	7,33
24B-2	38,1	1 1/2"	25,40	14,63	25,40	101,8	33,40	48,36	280,0	322,5	13,50
28B-2	44,45	1 3/4"	30,99	15,90	27,94	124,7	37,08	59,56	360,0	412,6	16,96
32B-2	50,8	2"	30,99	17,81	29,21	126,0	42,99	58,55	450,0	510,8	18,74
40B-2	63,5	2 1/2"	38,10	22,89	39,37	154,0	52,90	72,29	630,0	708,1	30,72

TRIPLA

ISO	p		b ₁ mm min.	d ₂ mm	d ₁ mm max.	a ₂ mm max.	g mm max.	e mm	Carga de rotura		q kg/m ≈
	mm	inch							minimo KN	medio KN	
06B-3	9,525	3/8"	5,72	3,28	6,35	34,0	8,26	10,24	24,9	27,7	1,12
08B-3	12,7	1/2"	7,75	4,45	8,51	44,9	11,81	13,92	47,5	56,0	1,94
10B-3	15,875	5/8"	9,65	5,08	10,16	52,8	14,73	16,59	66,7	83,3	2,68
12B-3	19,05	3/4"	11,68	5,72	12,07	61,7	16,13	19,46	86,7	101,5	3,32
16B-3	25,4	1"	17,02	8,28	15,88	99,9	21,08	31,88	160,0	202,8	7,65
20B-3	31,75	1 1/4"	19,56	10,19	19,05	116,1	26,42	36,45	250,0	306,5	10,96
24B-3	38,1	1 1/2"	25,40	14,63	25,40	150,2	33,40	48,36	425,0	490,6	20,20
28B-3	44,45	1 3/4"	30,99	15,90	27,94	184,3	37,08	59,56	530,0	625,9	25,38
32B-3	50,8	2"	30,99	17,81	29,21	184,5	42,99	58,55	670,0	775,0	28,04

CORRENTE DE ROLOS SERIE AMERICANA - DIN 8188 - ANSI B29.1 "ASA" ROLLER CHAINS AMERICAN STANDARD - DIN 8188 - ANSI B29.1 "ASA"

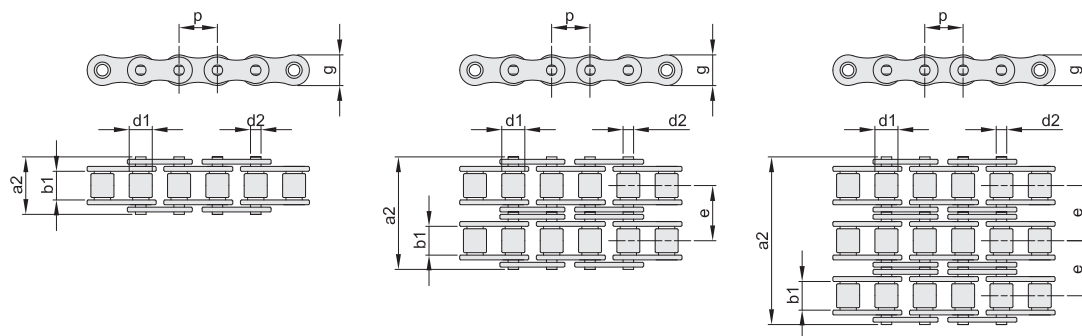

CORRENTE PRODUZIDA DE ACORDO COM NORMA ISO 9001 - ISO 14001 E API 7F
CHAIN PRODUCED BY ISO 9001 - ISO 14001 AND API 7F CERTIFIED COMPANY

CORRENTE PRÉ-TENSIONADA / PRE-STRETCHED CHAINS



SIMPLES

ANSI	p		b ₁ mm min.	d ₂ mm	d ₁ mm max.	a ₂ mm max.	g mm max.	Carga de rotura		q kg/m ≈
	mm	inch						minimo KN	medio KN	
35-1	9,525	3/8"	4,77	3,58	5,08	13,2	9,05	7,8	10,1	0,34
40-1	12,7	1/2"	7,95	3,96	7,92	17,8	12,07	14,1	18,8	0,63
50-1	15,875	5/8"	9,53	5,08	10,16	21,8	15,09	22,2	30,4	1,04
60-1	19,05	3/4"	12,70	5,94	11,91	26,9	18,08	31,8	41,7	1,52
80-1	25,4	1"	15,88	7,92	15,88	33,5	24,13	56,7	72,6	2,58
100-1	31,75	1"1/4	19,05	9,53	19,05	41,1	30,18	88,5	110,4	3,85
120-1	38,1	1"1/2	25,40	11,10	22,23	50,8	36,20	127,0	144,6	5,61
140-1	44,45	1"3/4	25,40	12,70	25,40	54,9	42,24	172,4	190,8	7,24
160-1	50,8	2"	31,75	14,27	28,58	65,5	48,26	226,8	253,4	9,91
60-1H	19,05	3/4"	12,70	5,94	11,91	31,2	18,08	31,2	42,1	1,81
80-1H	25,4	1"	15,88	7,92	15,88	38,0	24,13	55,6	72,6	3,00
100-1H	31,75	1"1/4	19,05	9,53	19,05	45,4	30,18	86,8	110,4	4,38

DUPLA

ANSI	p		b ₁ mm min.	d ₂ mm	d ₁ mm max.	a ₂ mm max.	g mm max.	e mm	Carga de rotura		q kg/m ≈
	mm	inch							minimo KN	medio KN	
35-2	9,525	3/8"	4,77	3,58	5,08	21,6	9,05	10,13	15,6	20,3	0,67
40-2	12,7	1/2"	7,95	3,96	7,92	32,3	12,07	14,38	28,2	37,7	1,26
50-2	15,875	5/8"	9,53	5,08	10,16	39,9	15,09	18,11	44,4	60,8	2,05
60-2	19,05	3/4"	12,70	5,94	11,91	49,8	18,08	22,78	63,3	83,4	3,01
80-2	25,4	1"	15,88	7,92	15,88	62,7	24,13	29,29	113,4	145,1	5,13
100-2	31,75	1"1/4	19,05	9,53	19,05	77,0	30,18	35,76	177,0	220,8	7,64
120-2	38,1	1"1/2	25,40	11,10	22,23	96,3	36,20	45,44	254,0	289,3	11,13
140-2	44,45	1"3/4	25,40	12,70	25,40	103,6	42,24	48,87	344,8	381,6	14,37
160-2	50,8	2"	31,75	14,27	28,58	124,2	48,26	58,55	453,6	506,7	19,68

TRIPLA

ANSI	p		b ₁ mm min.	d ₂ mm	d ₁ mm max.	a ₂ mm max.	g mm max.	e mm	Carga de rotura		q kg/m ≈
	mm	inch							minimo KN	medio KN	
35-3	9,525	3/8"	4,77	3,58	5,08	31,8	9,05	10,13	23,4	30,5	0,99
40-3	12,7	1/2"	7,95	3,96	7,92	46,7	12,07	14,38	42,3	56,6	1,98
50-3	15,875	5/8"	9,53	5,08	10,16	57,9	15,09	18,11	66,6	82,5	3,06
60-3	19,05	3/4"	12,70	5,94	11,91	72,6	18,08	22,78	95,4	120,1	4,50
80-3	25,4	1"	15,88	7,92	15,88	91,7	24,13	29,29	170,1	201,9	7,67
100-3	31,75	1"1/4	19,05	9,53	19,05	113,0	30,18	35,76	265,5	313,9	11,43
120-3	38,1	1"1/2	25,40	11,10	22,23	141,7	36,20	45,44	381,0	433,9	16,67
140-3	44,45	1"3/4	25,40	12,70	25,40	152,4	42,24	48,87	517,2	583,4	21,51
160-3	50,8	2"	31,75	14,27	28,58	182,9	48,26	58,55	680,4	760,1	29,45